



Load Capacities up to 80kg

- Pressed metal construction with special kingpin designed for shock absorption and durability
- Deep single large diameter ballrace for extra strength
- Large selection of wheels from 30mm to 63mm
- Foot operated side wheel brakes (suffix B) are available on most swivel castors
- 12 month warranty

Users include: Retailers, Caterers, Fabricators, Furniture manufacturers

Our Light Duty series is a strong but economical range that suits applications where minimal movement of light loads is required.

Frames

The frames are a pressed metal construction with a deep large single ballrace for extra strength. The special designed kingpin has been engineered for shock absorption and durability.

Foot operated side wheel brakes are available as optional extras for most sizes.

Frames are zinc plated to provide good corrosion resistance under normal operating conditions.

Wheels

A large selection of wheels is available to suit most applications. The range includes plastic, black or white nylon, hard or soft rubber and cast iron of varying diameters from 30mm to 63mm.

Where possible, castors are supplied with an axle and nut to provide easy replacement of wheel if required.

12 Month Warranty:

This range carries our standard 12 month warranty against faulty workmanship and materials, and is backed by a service and parts network Australia wide.



light duty

CASTORS

WHEEL SPECIFICATIONS						CASTOR SPECIFICATIONS							
Dia 'A'	Width 'B'	Wheel Type	Wheel Model No.	Bearing	Capacity	Height 'C'	Swivel Model No.	Rigid Model No.	Swept Radius 'D'	Radius 'K'	Plate Code	Product Code Swivel	Product Code Rigid
30	14	Plastic	K29900	Plain	14	40	K29901	-	22	N/A	S	-	-
40	18	Plastic	K20900	Nylon	27	56	K20901	K20902	40	N/A	T	-	-
50	24	Black Nylon	K21000	Plain	57	62	K21001	K21002	44	N/A	U	-	-
50	24	White Nylon	K21000W	Plain	57	62	K21001W	K21002W	44	N/A	U	-	-
50	24	Grey Rubber	K21100	Nylon	41	62	K21101	K21102	44	N/A	U	-	-
50	24	Soft Rubber	K21200	Nylon	41	62	K21201	K21202	44	N/A	U	-	-
50	24	Hard Rubber	K21300	Nylon	57	62	K21301	K21302	44	N/A	U	-	-
50	24	Cast Iron	K21500	Plain	57	62	K21501	K21502	44	N/A	U	04803106	-
50	24	Plastic	K21900	Plain	57	62	K21901	K21902	44	N/A	U	-	-
63	27	Black Nylon	K22000	Plain	80	83	K22001	K22002	60	N/A	V	03039114	-
63	27	Soft Rubber	K22200	Nylon	45	83	K22201	K22202	60	N/A	V	-	-
63	27	Hard Rubber	K22300	Nylon	80	83	K22301	K22302	60	N/A	V	-	-

Options:

Wheel brake, use suffix B after the swivel model number - i.e. K21001B

TECHNICAL SPECIFICATIONS

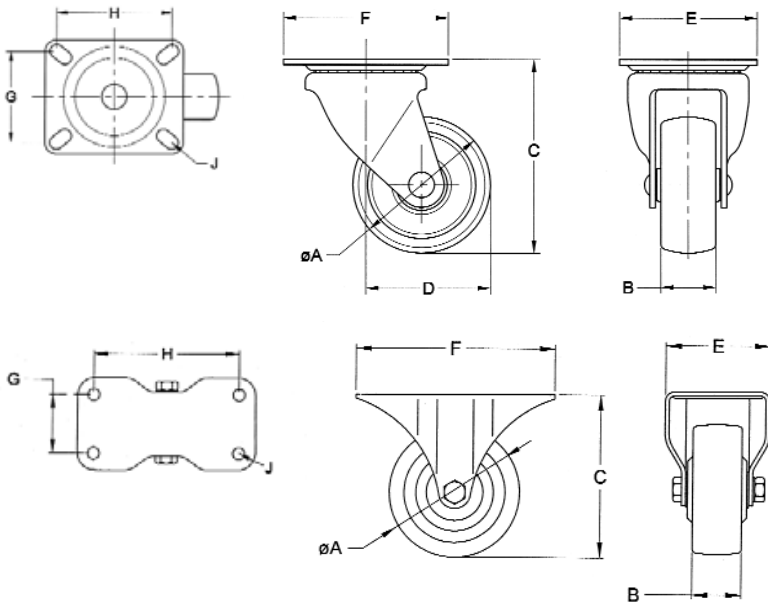

Top Plate Sizes and Bolt Hole Dimensions

All dimensions in millimetres except where shown

Plate Code	Swivel		Rigid		J
	E x F	G x H	E x F	G x H	
S	30 x 45	20 x 35	n/a	n/a	3/16"
T	38 x 55	27 x 44	38 x 55	27 x 44	3/16"
U	48 x 65	24 x 54	38 x 67.5	24 x 54	1/4"
V	70 x 98	45 x 76	57 x 113	27 x 89	5/16"



Models and specifications are subject to change without notice, all dimensions are nominal

® R.J. Cox Engineering
(02) 9486-3006

www.coxengineering.com.au
info@coxengineering.com.au

