

Load Capacities up to 180kg

- Fully fabricated steel frames provide optimum strength and durability
- Swivel castors have a precision machined deep grooved, sealed ballrace
- Various bearing options are provided to suit operating conditions
- Selection of quality pneumatic or cushion solid rubber tyres are available
- Australian made
- 12 month warranty

Users include: Large Factories with power trains, Baggage Handlers, Caterers

Pneumatic and cushioned solid rubber tyred castors are required where surface conditions or equipment carried requires some degree of impact absorption.

Frames

This range has fully welded steel frames, coupled with precision-machined deep grooved, swivel races to provide a product of strength and durability. The use of seals minimises maintenance requirements.

A limited range of castors featuring suspension frames is available where the need for impact absorption is critical.

Wheels

Sizes range from 212mm to 275mm with tyres ranging from 4ply pneumatic tyres to cushion solid rubber. The cushion solid rubber tyres provide a greater capacity while having the added advantage of being puncture proof.

Rims are manufactured in-house to provide a reliable, premium quality product.

12 Month Warranty

This range carries our standard 12 month warranty against faulty workmanship and materials, and is backed by a service and parts network Australia wide.



cushion tyred CASTORS

WHEEL SPECIFICATIONS						CASTOR SPECIFICATIONS							
Dia 'A'	Width 'B'	Wheel Type	Wheel Model No	Bearing	Capacity	Height 'C'	Swivel Model	Rigid Model	Swept Radius 'D'	'K'	Plate Code	Product Code Swivel	Product Code Rigid
212	64	Solid Rubber	L807	Roller	100	244	L417	L418	170	N/A	F	-	-
212	64	Solid Rubber	L805	Ball	100	244	L410	L411	170	N/A	F	04794105	04794202
220	45	Pneumatic	L808	Prec Ball	120/100	250	L415	L416	180	N/A	F	05064663	00746368
220	45	Pneumatic	L808	Prec Ball	80/80	270	L415SPR	L416SPR	210	N/A	F	-	-
230	50	Solid Rubber	L9250BHW-F	Prec Ball	180/140	255	L9550	L9551	190	N/A	F	-	-
230	50	Solid Rubber	L9250BHW-F	Prec Ball		276	L9550SPR	L9551SPR	216	N/A	F	-	00706996
230	50	Solid Rubber	L9250BHW-F	Prec Ball	120/120	276	L9552SPR	L9553SPR	216	N/A	F	03188255	00845784
260	72	Solid Rubber	L810	Ball	145	295	L420	L421	205	N/A	F	04794309	04794406
275	75	Pneumatic	L812	Prec Ball	180/160	298	L425	L426	220	N/A	F	00455141	00845070

TECHNICAL SPECIFICATIONS

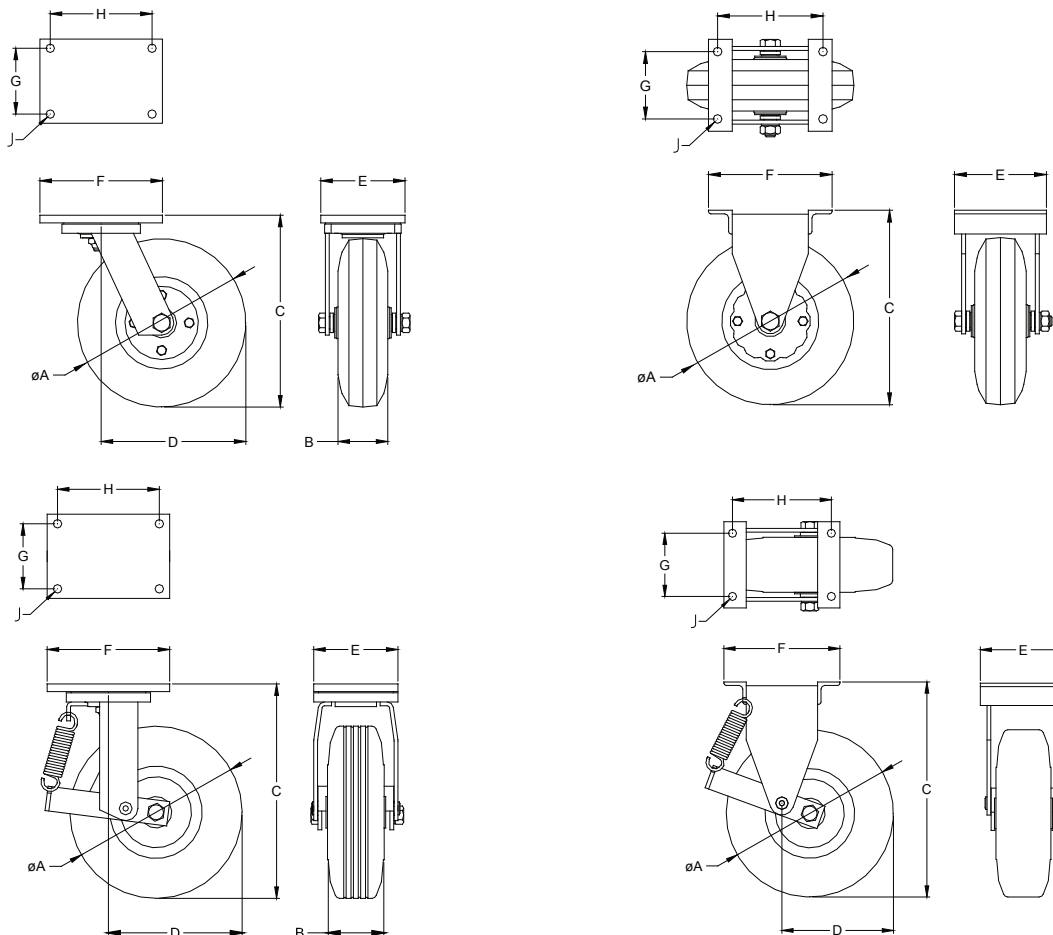

Top Plate Sizes and Bolt Hole Dimensions

All dimensions in millimetres except where shown

Plate Code	E x F	G x H	J
F	110 x 160	86 x 133	10



Models and specifications are subject to change without notice, all dimensions are nominal

R.J. Cox Engineering
(02) 9486-3006

www.coxengineering.com.au
info@coxengineering.com.au

