

## Type FS3-LG Fork Spreader & Load Guard

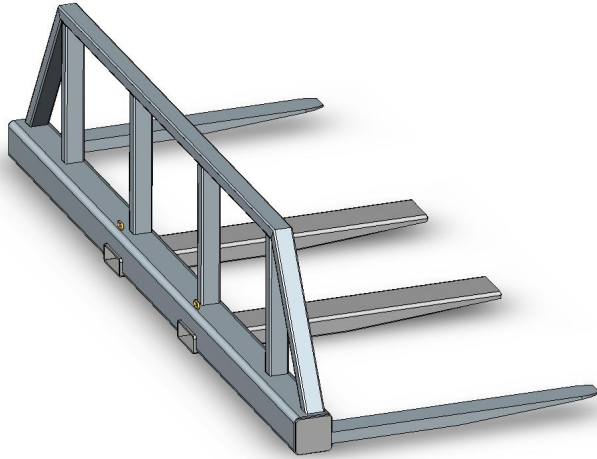

The type FS3-LG Fork Spreader & Load Guard has been designed to safely lift extra wide or flexible loads without the risk of damage to products such as plasterboard, roof sheeting, timber or plastic tubing etc. The Fork Spreader evenly distributes the load over its full length and has the extra benefit of a load guard incorporated into its design. This slip-on attachment is easily fitted onto the Lift Truck fork tines and is secured by a safety chain.

Fork Spreaders may be designed and manufactured to suit your application on request.

The standard finish on the type FS3-LG Fork Spreader & Load Guard is enamel painted over primed steel.

### SPECIFICATIONS:

- Pocket size 160 x 60mm
- Pocket Centres 775mm
- Safe Working Load 3000kg
- Load Centre 600mm
- Unit Weight 260kg
- HCG 300mm
- VCG 60mm

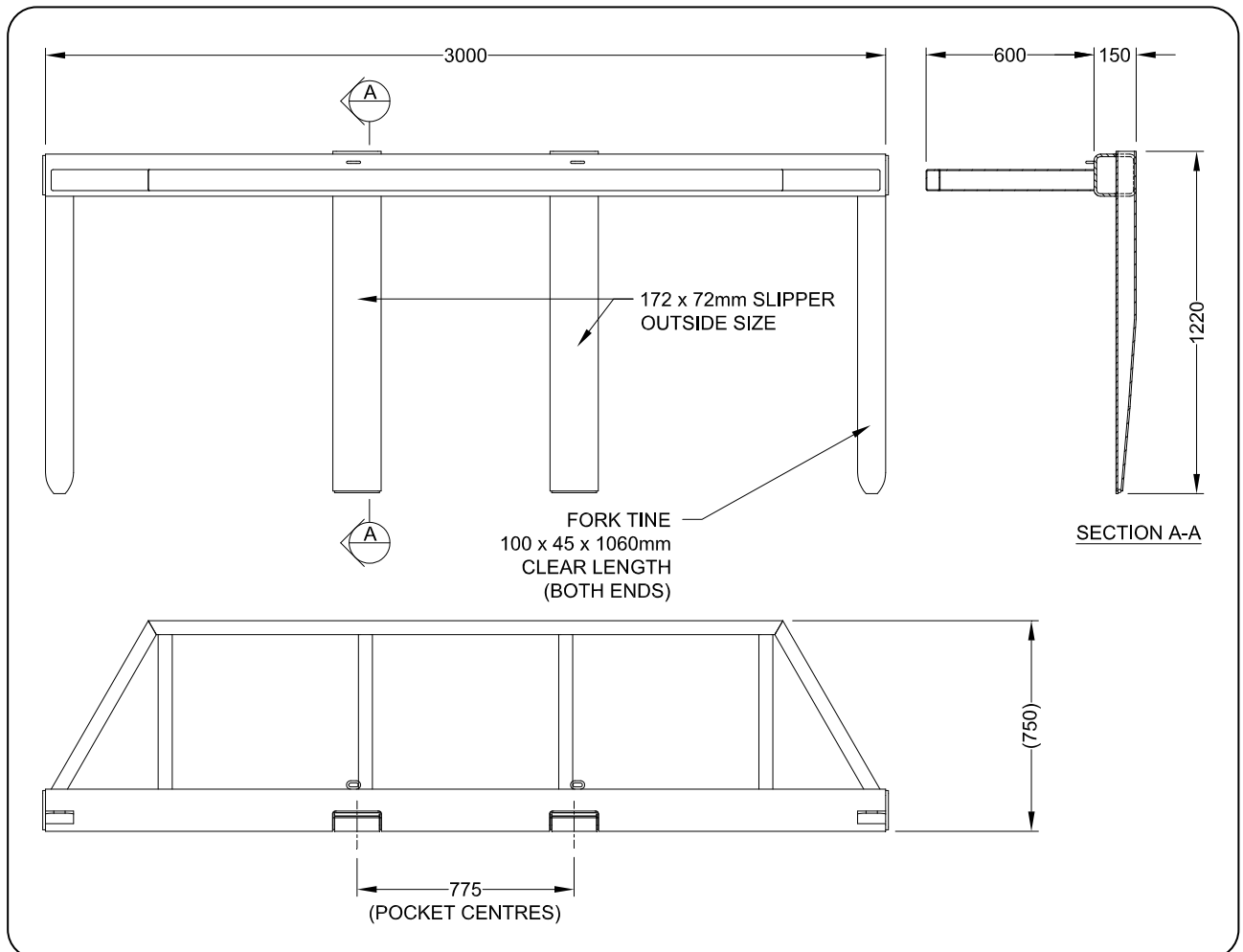

We Gladly Accept



*Proudly distributed by*

**RJ Cox Engineering**

[www.coxengineering.com.au](http://www.coxengineering.com.au)  
[info@coxengineering.com.au](mailto:info@coxengineering.com.au)

1 1

Ph: 02) 9486 3006  
Fax: 02) 9486 3009